

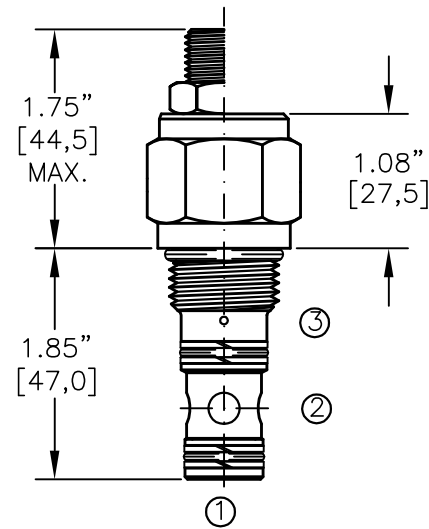

LOGIC CONTROL ELEMENT SPOOL TYPE, PILOT TO CLOSE, SPOOL "A".

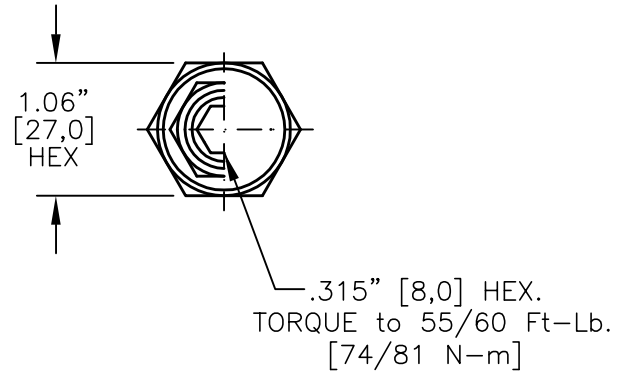
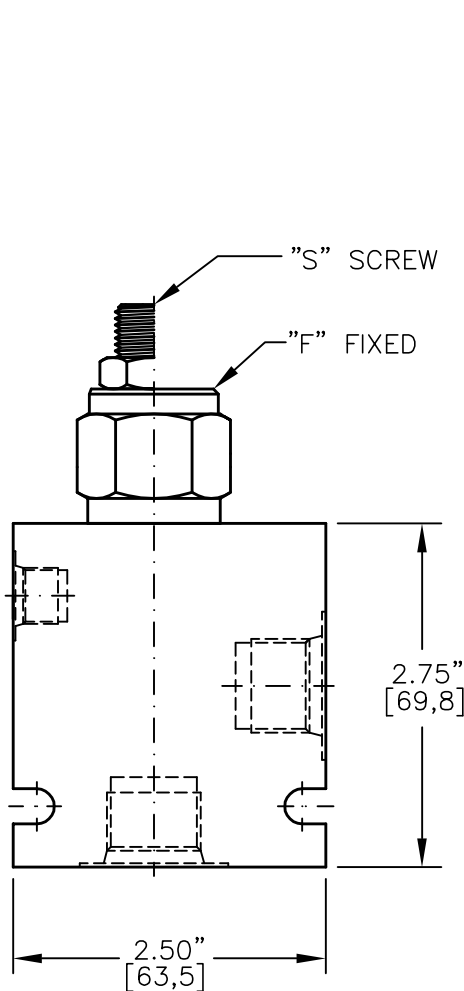
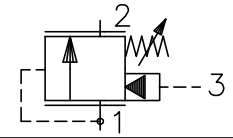

FOR ALUMINUM OR STEEL VALVE HOUSING CONFIGURATIONS SEE PAGE 0-022.1

LCEF-10-X-A-X-X-XXX

- BASIC SIZE
- 10 = 7/8"-14 UNF
- SEALS
- N = BUNA "N"
- V = VITON
- SPOOL
- "A"=SPOOL (PILOT TO CLOSE)
- ADJUSTMENT
- F = FIXED (FACTORY SET)
- S = ADJUSTING SCREW
- C = CAPPED
- T = TAMPERPROOF
- K = HANDKNOB
- M = METAL HANDKNOB
- FOR ADJUSTMENT CONTROL OPTIONS SEE PAGE 0-050.0

- PRESSURE BIAS SPRING
- 070 = 70 PSI (FIXED)
- 100 = 100 PSI (FIXED)
- 160 = 40-160 PSI (ADJ)
- PORTS
- 0 = CARTRIDGE ONLY
- 03BX = G 3/8" BSPP
- 04BX = G 1/2" BSPP
- 08TX = SAE - #8
- 10TX = SAE - #10
- "A" - ALUM. HOUSING
- "S" - STEEL HOUSING

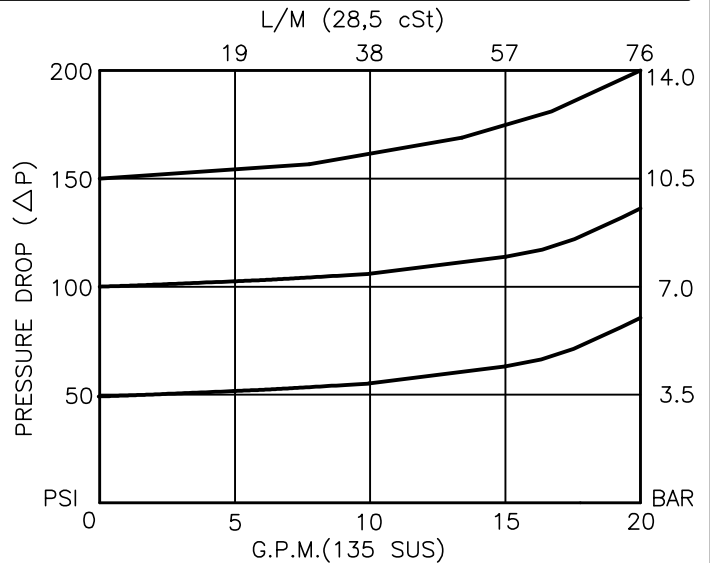



LOGIC CONTROL ELEMENT

SPOOL TYPE, PILOT TO CLOSE, SPOOL "A".

DESCRIPTION

This unit is a DIRECT ACTING, SCREW IN CARTRIDGE STYLE, SPOOL TYPE, HYDRAULIC DIRECTIONAL LOGIC ELEMENT, with multi-functional potential when used with other directional, pressure or flow control devices.

OPERATIONS

This valve blocks flow from port 1 to port 2 with a spring bias. It will shift to allow full flow from port 1 to port 2 only when the pressure in port 1 exceeds the cumulative pressure of port 3 plus the bias spring force value.

When no pressure is present at port 3, it will allow flow from port 1 to port 2 once the bias spring force is overcome by the pressure in port 1. This is pilot to close directional logic element.

FEATURES AND BENEFITS

Leakproof screw adjustment.

This valve has a fixed or an adjustable bias spring.

Adjustment screw can not be backed out of the valve.

Overset protection – spring can not go solid.

Hardened precision fitted spool & cage provides reliable, long life.

A unibody cage construction provides very low hysteresis and reliable operation.

All external carbon steel parts are plated for longer life against the elements. Valve is available with fixed, screw, tamperproof, capped and handknob adjustments.

All cartridge valves are 100% functionally tested.

Industry common cavity.

SPECIFICATIONS

OPERATING PRESSURE: 5,000 PSI [350 Bar]

PROOF PRESSURE: 10,000 PSI [700 Bar]

FLOW: 20.0 GPM [76 L/M] nominal. See performance chart.

INTERNAL LEAKAGE: 5 cu.in./min. [85 cc/m] @ 85% of crack pressure.

DEFINITION OF CRACK: evident at 0.06 GPM [0.25 LPM]

VALVE HOUSINGS: 2500 PSI [175 Bar] = Aluminum – Anodized.

5000 PSI [350 Bar] = Steel – Unplated.

OPERATING TEMPERATURE: -40° to +250° F. [-40° to +120° C.]

OPERATING MEDIA: All general purpose hydraulic fluids such as MIL-H-5606, SAE-#10, SAE-#20, etc.

INSTALLATION: No restriction.

FILTRATION: 25 microns or better.

SEAL KIT NUMBER: SKN-1027 for buna "N".

SKV-1027 for viton.

WEIGHT: 0.46 lb [.21 kg] cartridge only.

VALVE CAVITY: #C1025, See Page 0-022.0.